

Circular Motion

1. What is the centripetal acceleration of the Moon in its orbit around the Earth?

2. A 0.055 kg puck is attached to a 0.150 kg mass **M** by a cord that passes through a hole in a frictionless table, as shown. The puck travels in a circular path of radius 0.25 m. What is the speed of the puck?

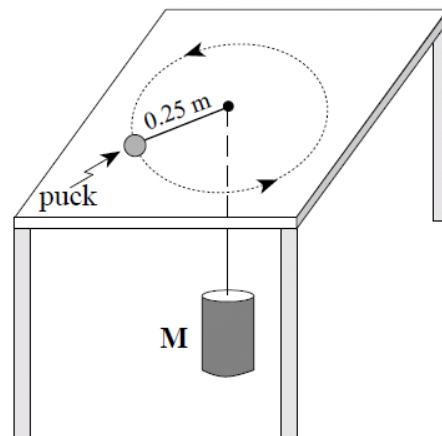

3. On Earth, the maximum speed without skidding for a car on a level circular curved track of radius 40 m is 15 m/s. This car and track are then transported to another planet for the Indy Galactic 500. The maximum speed without skidding is now 8.4 m/s. What is the value of the acceleration due to gravity on this other planet?

A. 1.8 m/s^2
 B. 3.1 m/s^2
 C. 4.3 m/s^2
 D. 5.5 m/s^2

4. A 500 N child travels in a circular path on a ferris wheel. Which free body diagram **best** shows the forces which could act on the child as she passes the lowest point?

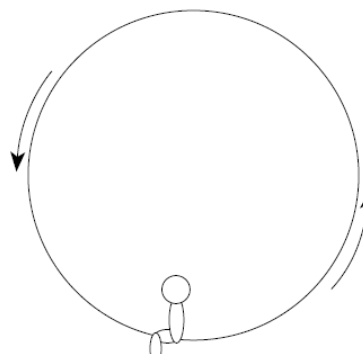
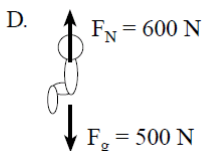
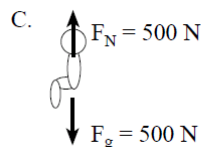
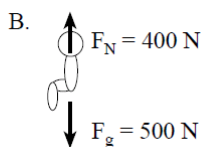
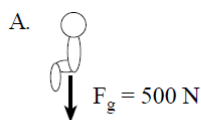

5. The diagram shows a toy plane flying in a circle of radius 1.20 m, supported by a string which makes an angle of 28° with the vertical. The tension in the string is 1.80 N.
- a) What is the mass of the plane?

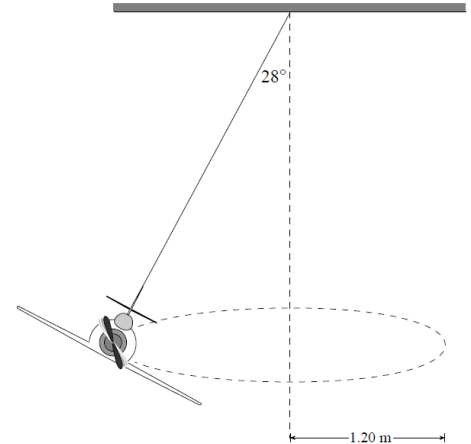

- b) How long does the plane take to complete one orbit?

Assignment

6. An object of mass m is on a horizontal rotating platform. The mass is located 0.22 m from the axle and makes one revolution every 0.74 s. The friction force needed to keep the mass from sliding is 13 N. What is the object's mass?

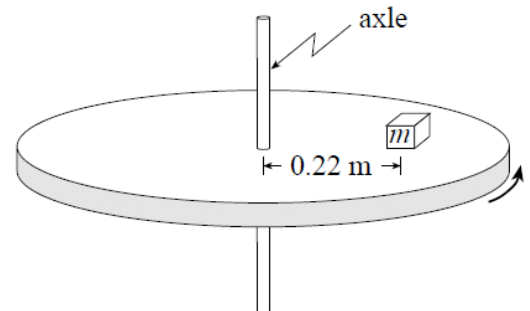

7. A 35 kg child rides a ferris wheel of radius 12 m. The child moves in a vertical circle at a constant speed and completes one rotation every 9.0 s.
- a) As the child travels over the top, what is the magnitude of the force that the seat exerts on the child?

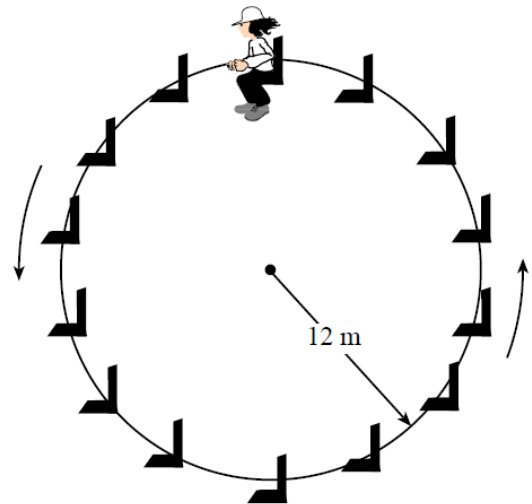

- b) How does the magnitude of the child's acceleration at the top of the ride compare to her acceleration at the bottom? The child's acceleration at the top is: (circle one)
- i) less than at the bottom.
 - ii) greater than at the bottom.
 - iii) the same as at the bottom.

Explain your choice using principles of physics.

8. A 1.2 kg mass on the end of a string is rotated in a vertical circle of radius 0.85 m. If the speed of the mass at the top of the circle is 3.6 m/s, what is the tension in the string at this location?
- A. 6.5 N
 B. 12 N
 C. 18 N
 D. 30 N

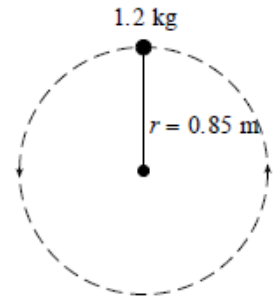

9. A person is on a horizontal rotating platform at a distance of 4.3 m from its centre. This person experiences a centripetal acceleration of 5.6 m/s^2 . What centripetal acceleration is experienced by another person who is at a distance of 2.5 m from the centre of the platform?

10. What is the magnitude of the centripetal acceleration of the earth as it orbits the sun?
- A. $3.4 \times 10^{-18} \text{ m/s}^2$
 B. $1.8 \times 10^{-8} \text{ m/s}^2$
 C. $5.9 \times 10^{-3} \text{ m/s}^2$
 D. 9.8 m/s^2

11. A 61 kg skateboarder is moving down a ramp with a 7.0 m radius of curvature. At the bottom of this ramp he reaches a speed of 7.8 m/s. What upward force acts on the skateboarder at the bottom of the ramp?
- A. $7.0 \times 10^1 \text{ N}$
 B. $5.3 \times 10^2 \text{ N}$
 C. $6.0 \times 10^2 \text{ N}$
 D. $1.1 \times 10^3 \text{ N}$

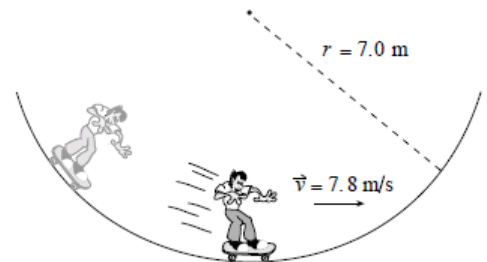

12. A 3.5 kg object is suspended by a string and moves in a horizontal circle of radius 0.60 m. The tension in the string is 36 N.

a) What is the magnitude of the net force on the object?

b) What is the period of revolution of the object?

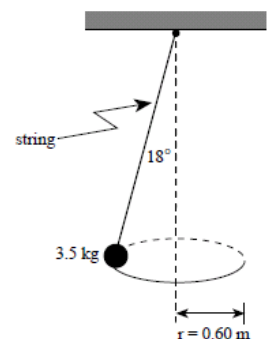

Enrichment

13. A 9.0×10^{-3} kg ball is attached to a 3.6×10^{-2} kg mass M by a string that passes through a hole in a horizontal frictionless surface. The ball travels in a circular path of radius 0.35 m. What is the speed of the ball?

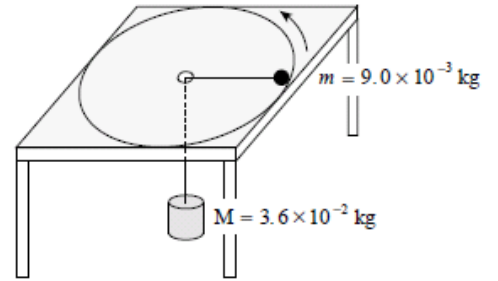

- A. 0.93 m/s
- B. 1.9 m/s
- C. 3.7 m/s
- D. 4.1 m/s

14. A space station has an outer radius of 140 m. The station rotates so that the occupants at X at the outer wall experience an acceleration of 9.8 m/s^2 . What acceleration will the occupants at Y experience at the 100 m radius?

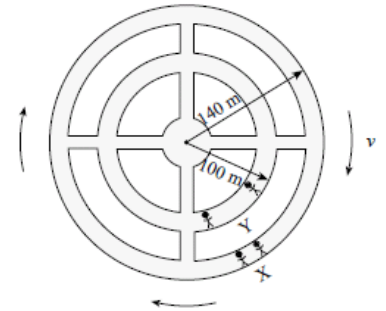

- A. 7.0 m/s^2
- B. 8.3 m/s^2
- C. 9.8 m/s^2
- D. 14 m/s^2

15. A 65 kg student is in a car travelling at 25 m/s on a hill of radius 110 m. When the car is at the top of the hill, what upward force does the seat exert on the student?



- A. 270 N
- B. 370 N
- C. 640 N
- D. 910 N

Answers: 1) $2.7 \times 10^{-3} \text{ m/s}^2$, 2) 2.6 m/s, 3) B, 4) D, 5a) 0.16 kg, b) 3.0 s, 6) 0.82 kg, 7) 138 N, b) iii, 8) A, 9) 3.3 m/s^2 , 10) C, 11) D, 12a) 11N, b) 2.7s, 13) C, 14) A, 15) A