

**Dynamics Review**

1.

A 75 kg man stands on a scale while accelerating upwards in an elevator. If the scale reads 850 N, what is the magnitude of the acceleration of the elevator?

- A.  $1.2 \text{ m/s}^2$
- B.  $1.5 \text{ m/s}^2$
- C.  $9.8 \text{ m/s}^2$
- D.  $11 \text{ m/s}^2$

2.

A 45 kg toboggan and rider decelerate on level snow at  $0.53 \text{ m/s}^2$ . What is the coefficient of friction between the toboggan and the snow?

- A. 0.012
- B. 0.054
- C. 0.22
- D. 0.53

3.

The 4.0 kg block shown accelerates across a frictionless horizontal table at  $1.5 \text{ m/s}^2$ .

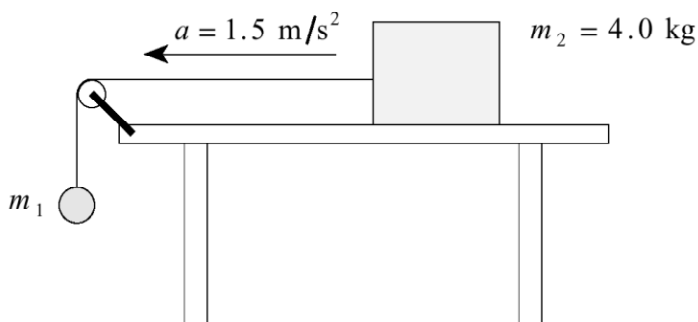

Find the mass of object  $m_1$ .

- A. 0.61 kg
- B. 0.72 kg
- C. 6.0 kg
- D. 26 kg

4.

Which of the following is **not** a statement of one of Newton's laws of motion?

- A. For every action force, there is an equal and opposite reaction force.
- B. If no net force acts on an object, the object will remain at rest, or continue to move at a constant velocity.
- C. The acceleration of freely falling objects is proportional to their mass.
- D. If a net force does act on an object, the object will accelerate in the direction of the net force.

5.

Three blocks have masses 1.0 kg, 7.0 kg and 5.0 kg as shown. The horizontal surface is frictionless.

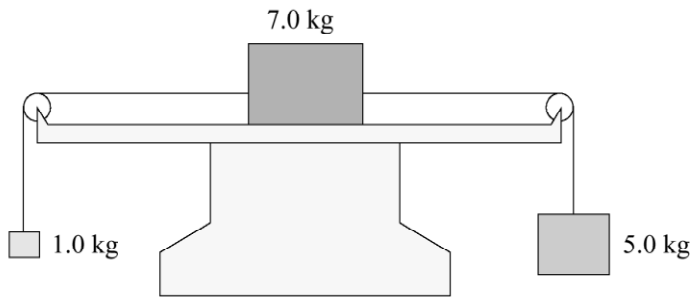

What is the magnitude of the acceleration of the system?

- A.  $3.0 \text{ m/s}^2$
- B.  $3.8 \text{ m/s}^2$
- C.  $6.5 \text{ m/s}^2$
- D.  $7.8 \text{ m/s}^2$

6.

A 2.0 kg block is sliding down a  $15^\circ$  incline. The coefficient of friction is 0.62. At some position the block has a speed of 7.0 m/s.

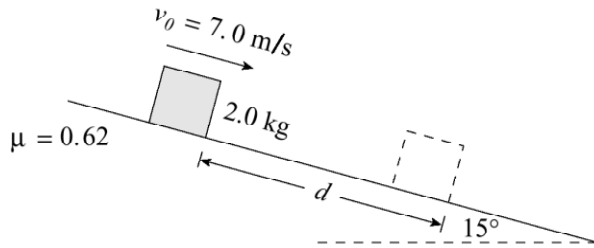

What distance  $d$  will this block move before coming to rest?

- A. 2.5 m
- B. 4.0 m
- C. 4.2 m
- D. 7.4 m

7.

In the diagram shown, the tension in the cord connecting the hanging mass and cart is 43 N.

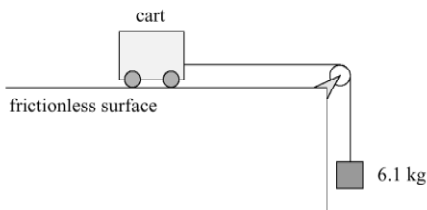

a) Draw and label a free body diagram for the cart and the hanging mass. (2 marks)



b) Determine the mass of the cart.

(5 marks)

8.

A student exerts a 120 N horizontal force on a 25 kg carton of apples, causing it to accelerate over level ground at  $1.8 \text{ m/s}^2$ .

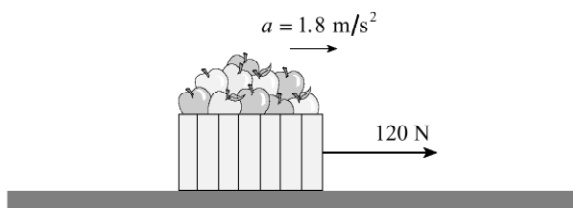

Find the coefficient of friction between the carton and the ground.

- A. 0.31
- B. 0.38
- C. 0.49
- D. 0.67

9.

A net force  $F$  acts on an object of mass  $m$ , causing it to accelerate at  $4.0 \text{ m/s}^2$ . If the same net force  $F$  acts on an object of mass  $2m$ , its acceleration will be

- A.  $1.0 \text{ m/s}^2$
- B.  $2.0 \text{ m/s}^2$
- C.  $4.0 \text{ m/s}^2$
- D.  $8.0 \text{ m/s}^2$

10.

A student drags a 7.0 kg carton of apples across the floor by exerting a 45 N force in the direction shown. The coefficient of friction between the carton and the floor is 0.52.

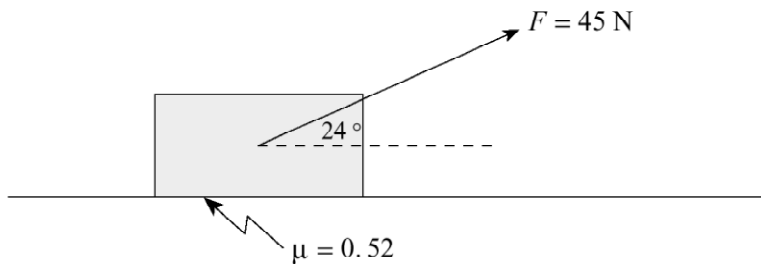

- a) What is the magnitude of the normal force acting on the carton?
- b) What friction force acts on the cart?
- c) What is the acceleration of the cart?

11.

A 72 kg skydiver drops from a helicopter and is accelerating downwards at  $8.6 \text{ m/s}^2$ . Find the friction force acting on him.

- A. 86 N
- B. 620 N
- C. 710 N
- D. 1 300 N

12.

The diagram shows two objects connected by a light string over a frictionless pulley. Object  $m_2$  is on a frictionless horizontal table. The tension in the string is 24 N.

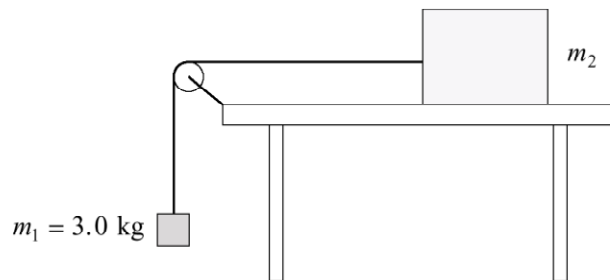

a) Find the acceleration of the system.

**(4 marks)**

b) Find the mass of  $m_2$ .

**(3 marks)**

13.

A girl applies a 140 N force to a 35 kg bale of hay at an angle of  $28^\circ$  above horizontal. The friction force acting on the bale is 55 N. What will be the horizontal acceleration of the bale?

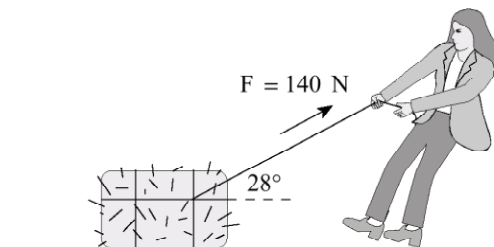

- A.  $0.31 \text{ m/s}^2$
- B.  $2.0 \text{ m/s}^2$
- C.  $2.4 \text{ m/s}^2$
- D.  $2.6 \text{ m/s}^2$

14.

A 5.0 kg concrete block accelerates down a  $34^\circ$  slope at  $4.2 \text{ m/s}^2$ . Find the coefficient of friction between the block and the slope.

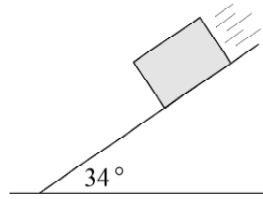

- A. 0.13
- B. 0.16
- C. 0.43
- D. 0.67

15.

A block is on a frictionless incline.

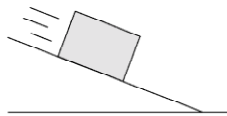

Which of the following is a correct free body diagram for the block?

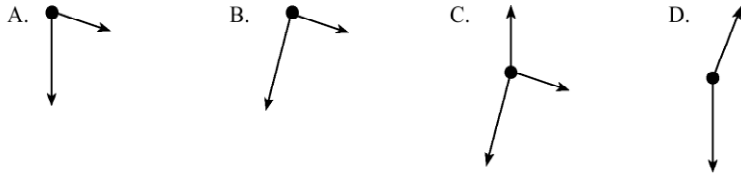

20.

A 5 500 kg helicopter is travelling at constant speed in level flight.

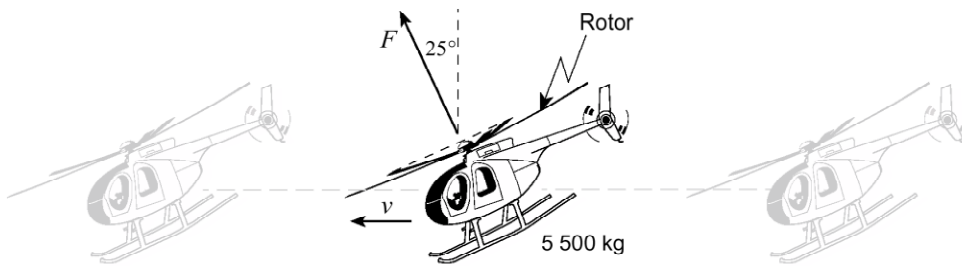

What is the force  $F$  provided by the rotor?

- A.  $4.9 \times 10^4 \text{ N}$
- B.  $5.4 \times 10^4 \text{ N}$
- C.  $5.9 \times 10^4 \text{ N}$
- D.  $1.2 \times 10^5 \text{ N}$

22.

Which of the following graphs shows the relationship between acceleration and net force?

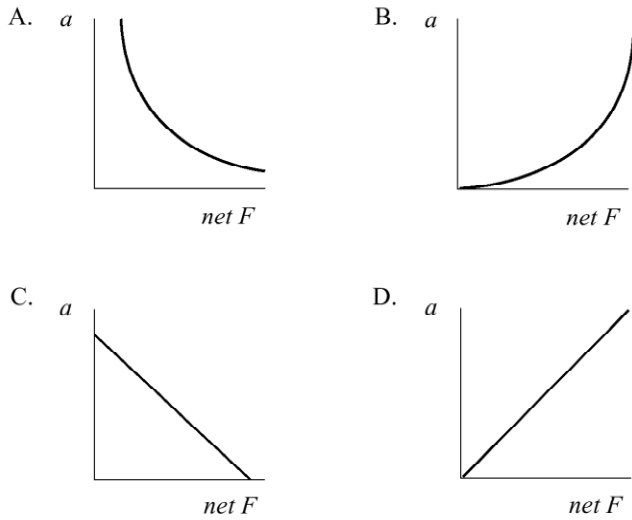

23.

A 12 kg cart on a  $23^\circ$  frictionless incline is connected to a wall as shown.

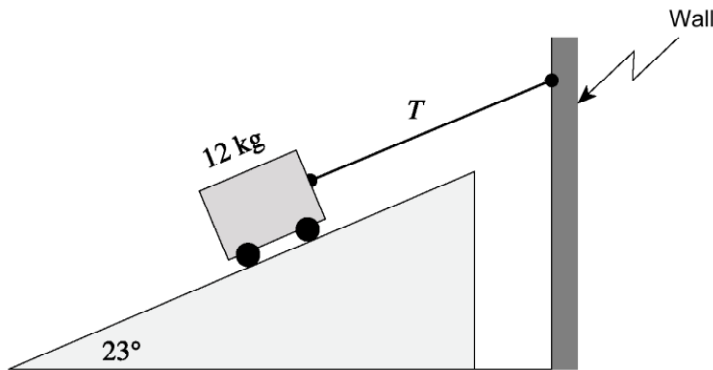

What is the tension  $T$  in the cord?

- A. 46 N
- B. 50 N
- C. 110 N
- D. 120 N

25.

A block of mass  $m$  remains at rest on an incline as shown in the diagram.

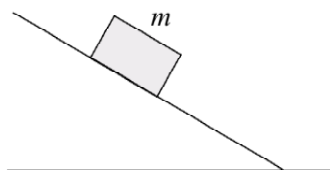

The force acting up the ramp on this block is

- A. 0.
- B.  $mg$ .
- C. less than  $mg$ .
- D. more than  $mg$ .

28.

A curling rock is travelling to the right across the ice as shown in the diagram.

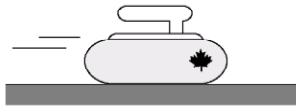

Which of the following best represents the forces acting on the curling rock?

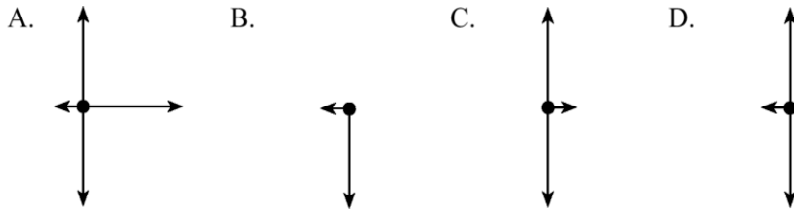

30.

The system of blocks on a frictionless surface in the diagram below is accelerating at  $2.0 \text{ m/s}^2$ .

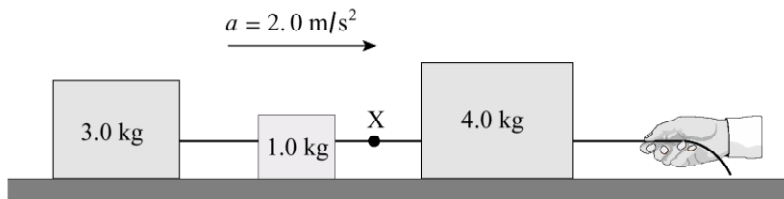

What is the tension in the cord at X?

- A. 2.0 N
- B. 6.0 N
- C. 8.0 N
- D. 16 N

39.

Two masses are connected by a light string which passes over a frictionless pulley as shown. The coefficient of friction between the 2.5 kg mass and the surface is 0.33.

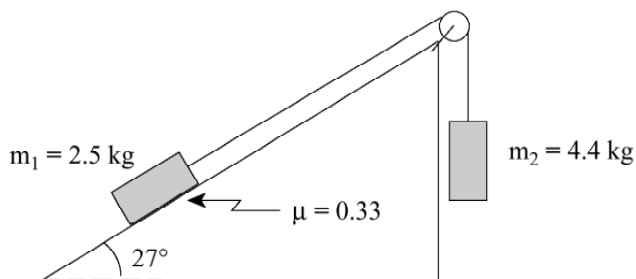

a) Find the acceleration of the system of masses. (7 marks)

b) Find the tension in the string. (5 marks)

**Answers:**

- |  |   |
|--|---|
| 1. b   | 21. b   |
| 2. b   | 22. d   |
| 3. b   | 23. a   |
| 4. c   | 24. a) see my key b) $7.3 \text{ m/s}^2$                    |
| 5. a   | 25. c   |
| 6. d   | 26. a) see my key b) $5.7 \text{ m/s}^2$                    |
| 7. a) see my solution b) $m=16 \text{ kg}$                         | 27. c   |
| 8. a   | 28. d   |
| 9. b   | 29. b   |
| 10. a) $50.3 \text{ N}$ b) $26.2 \text{ N}$ c) $2.1 \text{ m/s}^2$ | 30. c   |
| 11. a  | 31. a   |
| 12. a) $1.8 \text{ m/s}^2$ b) $13.3 \text{ kg}$                    | 32. d   |
| 13. b  | 33. b   |
| 14. b  | 34. d   |
| 15. d  | 35. b) $3.24 \text{ m/s}^2$ c) $4.76 \times 10^3 \text{ N}$ |
| 16. b  | 36. $4.6 \text{ m/s}^2$                                     |
| 17. $1.7 \text{ m/s}^2$  | 37. $7.0 \times 10^2 \text{ m}$                             |
| 18. a  | 38. a) $0.249$ b) $3.27 \text{ m/s}^2$                      |
| 19. b  | 39. a) $3.6 \text{ m/s}^2$ b) $27.3 \text{ N}$              |
| 20. c  | 40. a) $0.83 \text{ m/s}^2$ b) $0.27$                       |